

DIN3352F4 NRS Metallic seated Cast Iron Gate valve

SPECIFICATIONS

Size	DN 40 - 300
Class	PN 10 - PN 16
Design	DIN3352
Face to Face	DIN3202 F4/ISO 5752 14 Series
End Flange	BS 4504 / BS EN 1092
Test	DIN3352

STANDARD MATERIALS OF MAIN PARTS

ITEM	PART NAME	MATERIAL
1	Body	Ductile Iron
2	Wedge	Ductile Iron
3	Bonnet	Ductile Iron
4	Stem	Stainless Steel 420
5	Stem Nut	Brass
6	Holding Ring	Brass
7	Sealing Ring	Brass
8	Body Ring	Brass
9	Wedge Ring	Brass
10	Gland	Ductile Iron
11	Handwheel	Ductile Iron
12	Bonnet Gasket	NBR
13	O Ring	NBR
14	Dust Ring	NBR

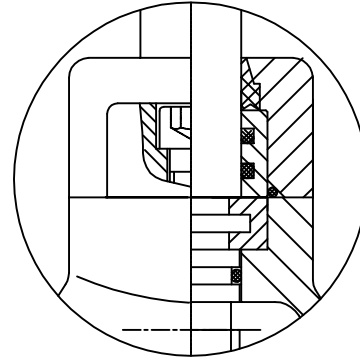
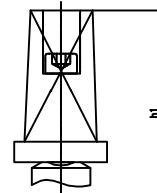
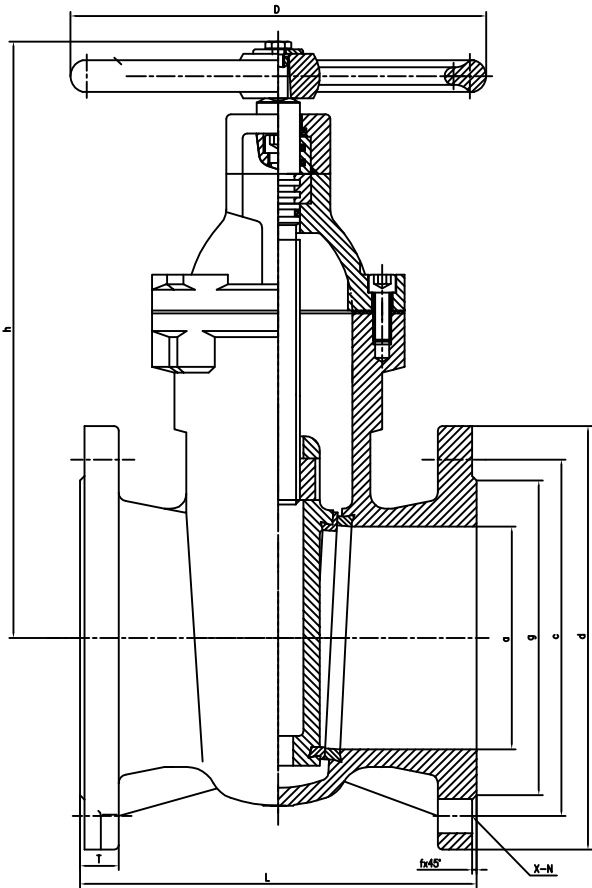

DIMENSIONS

DN	OUTLINE mm				END FLANGE BS PN10/16 mm				BS PN10/16 mm			
	L	h	D	h1	a	d	c	x-n	T	g	f	
40	140	225	150	270	40	150	110	4- ϕ 19	19	84	3	
50	150	235	150	280	50	165	125	4- ϕ 19	19	99	3	
65	170	265	150	310	65	185	145	4- ϕ 19	19	118	3	
80	180	290	180	335	80	200	160	8- ϕ 19	19	132	3	
100	190	325	180	370	100	220	180	8- ϕ 19	19	156	3	
125	200	390	240	435	125	250	210	8- ϕ 19	19	184	3	
150	210	435	280	480	150	285	240	8- ϕ 23	19	211	3	
200	230	530	320	575	200	340	295	8- ϕ 23 12- ϕ 23	20	266	3	
250	250	590	360	635	250	405	350 355	12- ϕ 23 12- ϕ 28	22	319	3	
300	270	720	450	765	300	460	400 410	12- ϕ 23 12- ϕ 28	24.5	370	4	