

# Resilient Seat Gate Valve

# Socket End NRS

## SPECIFICATIONS

Size	DN 50 - 300
Class	PN 10 - PN 16
Design	DIN 3352
Face to Face	ISO 5752 15 Series
Socket End	Suitable for PVC Tube
Test	DIN 3230

## STANDARD MATERIALS OF MAIN PARTS

ITEM	PART NAME	MATERIAL
1	Body	Ductile Iron
2	Disc	Ductile Iron+EPDM
3	Bonnet	Ductile Iron
4	Stem	Stainless Steel 420
5	Stem Nut	Brass
6	Holding Ring	Brass
7	Sealing Ring	Brass
8	Handwheel	Ductile Iron
9	Bonnet Gasket	NBR
10	O Ring	NBR
11	Dust Ring	NBR

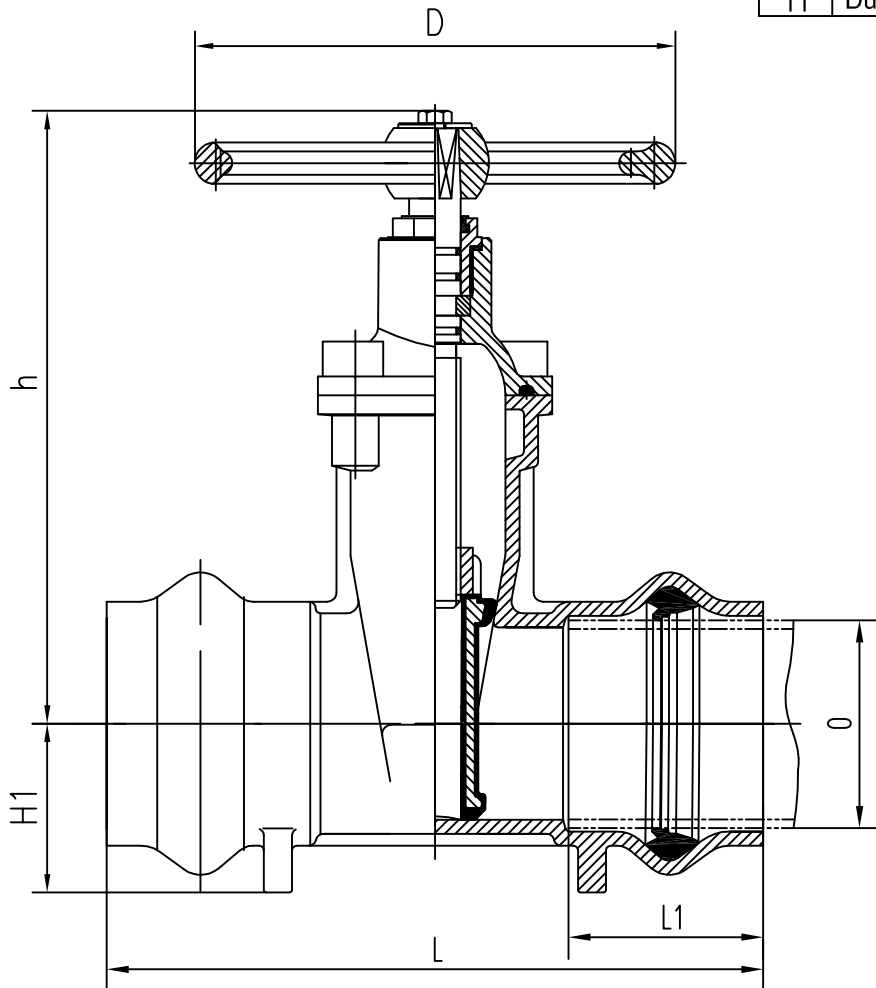

## DIMENSIONS

DN	PVC Tube Ø	L	L1	h	D	H1	
50	63	250	77	205	150	50	
65	75	270	80	228	150	58	
80	90	280	84	265	180	72	
100	110	300	88	300	205	80	
125	125	325	91	355	205	90	
	140	325	91	355	205	90	
150	160	350	94	400	240	110	
200	200	400	100	490	280	135	
	225	400	100	490	280	135	
250	250	450	125	585	320	160	
300	315	500	140	685	360	195	