

BS5153 NRV Metallic seated Swing Check valve

STANDARD MATERIALS OF MAIN PARTS

ITEM	PART NAME	MATERIAL
1	Body	Ductile Iron GGG50
2	Di sc	Ductile Iron GGG50
3	Cover	Ductile Iron GGG50
4	Shaft/Pi n	Stainless Steel 420
5	Shaft Nut	Ductile Iron GGG50
6	Hi nge	Ductile Iron GGG50
7	Body Ring	Brass
8	Di sc Ring	Brass

SPECIFICATIONS

Size	DN50 - 400
Class	PN 10 - PN 16
Design	BS 5153
Face to Face	BS 5153
End Flange	BS 4504 / BS EN 1092
Test	BS 5153

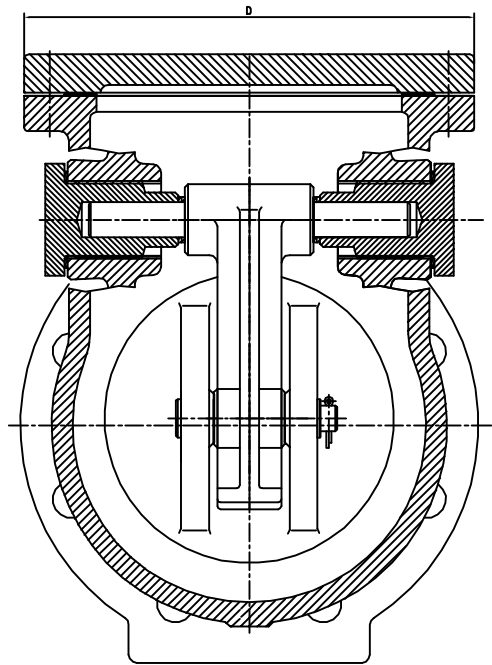
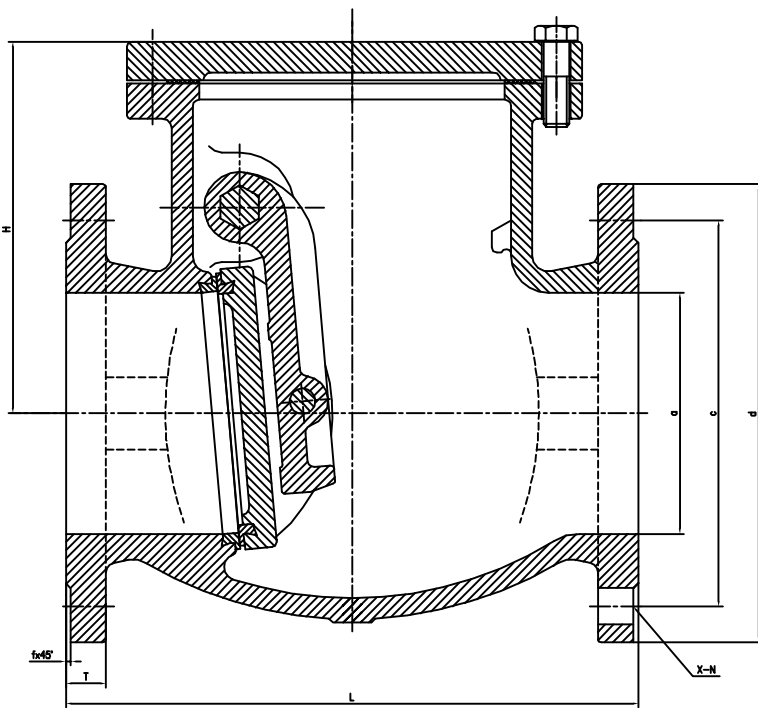

DIMENSION

SIZE	a	c	d	T	f	L	X-N(PN10/PN16)		≈H	D
50	50	125	165	19	3	203	4-∅19		135	170
65	65	145	185	19	3	216	4-∅19		148	176
80	80	160	200	19	3	241	8-∅19		178	205
100	100	180	220	19	3	292	8-∅19		195	220
125	125	210	250	19	3	330	8-∅19		210	265
150	150	240	285	19	3	356	8-∅23		250	295
200	200	295	340	20	3	495	8-∅23	12-∅23	300	370
250	250	355	405	22	3	622	12-∅23	12-∅27	335	430
300	300	410	460	24.5	4	698	12-∅23	12-∅27	365	505
350	350	470	520	26.5	4	787	16-∅23	16-∅27	415	610
400	400	525	580	28	4	914	16-∅28	16-∅31	455	685